



RASCAL

Parts Diagram
&
Service Manual

Tools, Pivot Numbers & Torque Specifications

Required Tools for Basic Service

- Torque Wrench
- 1x 4mm Hex Wrench
- 1x 4mm Hex Bit
- 1x 5mm Hex Bit
- 1x 6mm Hex Bit
- 1x 8mm Hex Bit

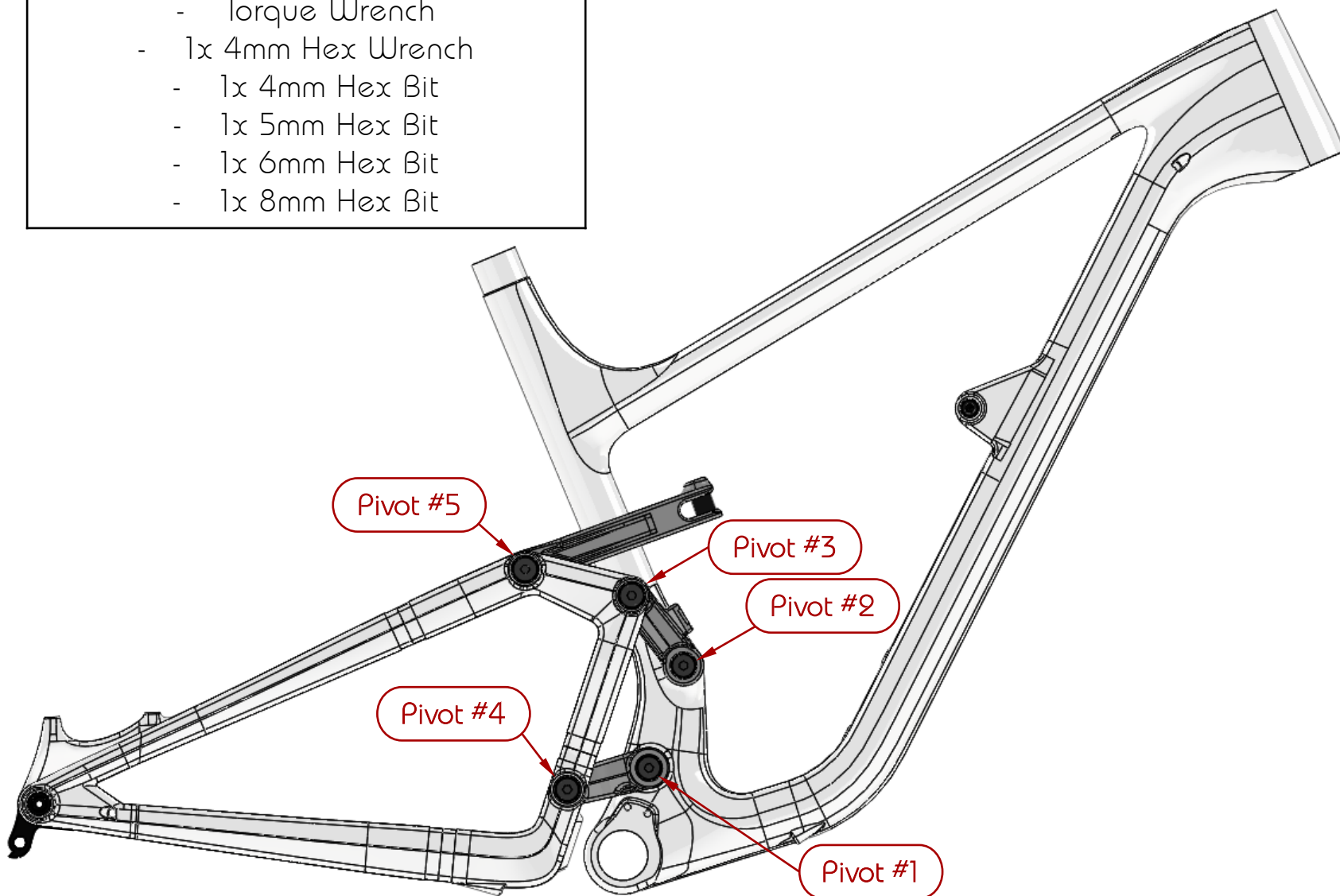

Torque Specifications

Pivot #1	10 Nm
Pivot #2	10 Nm
Pivot #3	10 Nm
Pivot #4	10 Nm
Pivot #5	10 Nm
Rear Shock Bolt	15 Nm
Forward Shock Bolt	10 Nm
Rear Axle	13 Nm (18 Nm Max)
Seat Clamp	5 Nm
Derailleur Hanger	5 Nm

Exploded View & Parts List

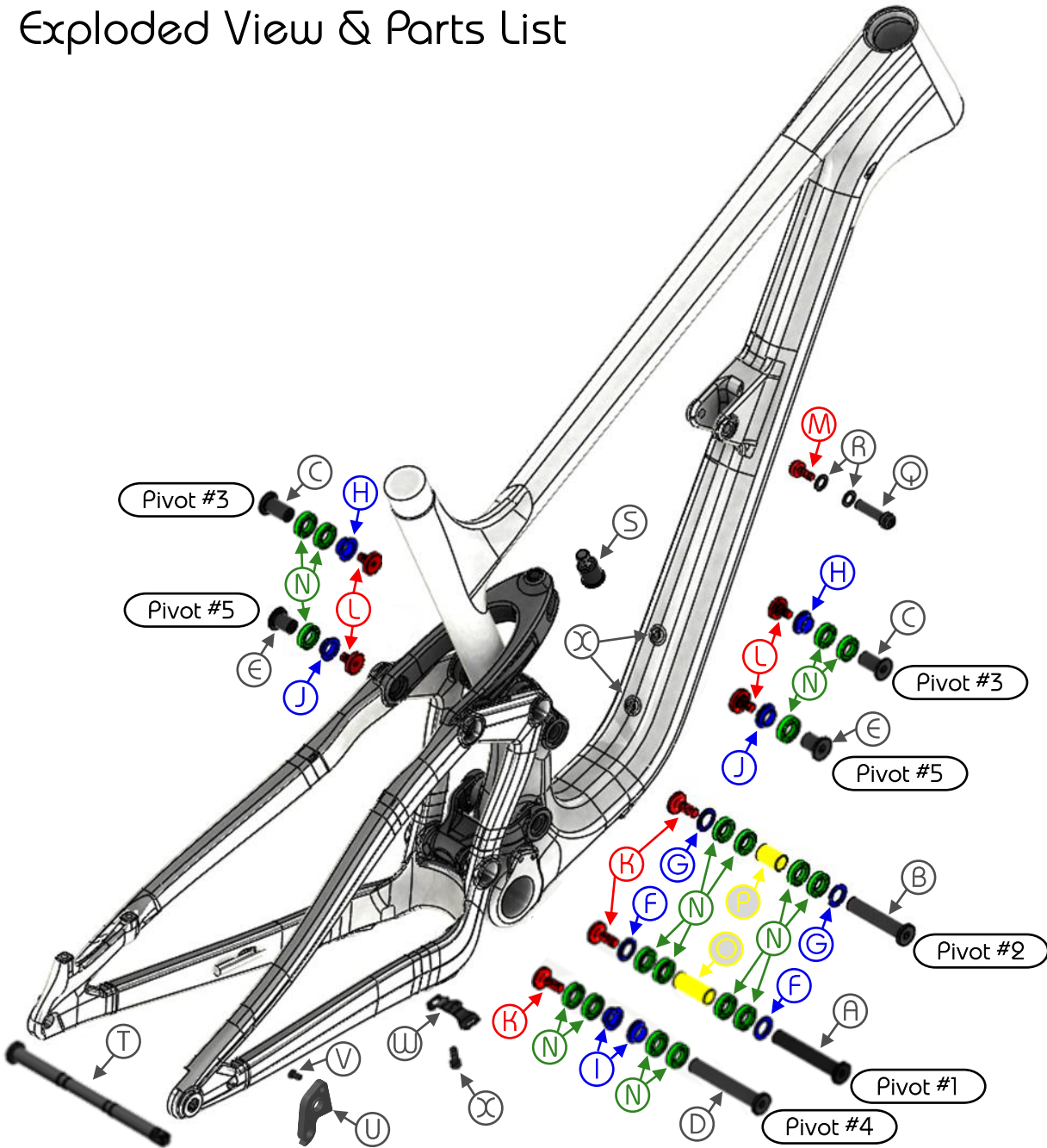

	Part Number	Description	Qty.
A	310-FRA18-0116	Pivot #1 Axle	1
B	310-FRA18-0120	Pivot #2 Axle	1
C	310-FRA18-0122	Pivot #3 Axle	2
D	310-FRA18-2124	Pivot #4 Axle	1
E	310-FRA18-0126	Pivot #5 Axle	2
F	310-FRA18-0115	Pivot #1 Spacer	2
G	310-FRA18-0119	Pivot #2 Spacer	2
H	310-FRA18-0121	Pivot #3 Spacer	4
I	310-FRA18-2123	Pivot #4 Spacer	2
J	310-FRA18-0125	Pivot #5 Spacer	4
K	310-FRA18-0117	Pivot #1/#2/#4 Bolt	3
L	310-FRA18-0127	Pivot #3/#5 Bolt	4
M	310-10021-0050	Forward Shock Bolt	1
N	-----	6801V Bearing	18
O	310-FRA18-0114	Pivot #1 Inner Spacer	1
P	310-FRA18-0118	Pivot #2 Inner Spacer	1
Q	310-10021-0051	Forward Shock Axle	1
R	310-FRA18-0129	Forward Shock Washers	2
S	310-10021-0077	Rear Shock Bolt	1
T	310-00000-0028	Revel Axle	1
U	310-HAN18-0107	Rail/Rascal Derailleur Hanger	1
V	310-HAN18-0108	Rail/Rascal Derailleur Hanger Bolt	1
W	310-FRA18-0111	Downtube Hose Clamp	1
X	-----	Hose Clamp/Bottle Mount Bolts	5

Pivot Assembly Overview

- ✗ When servicing your Rascal's linkage, take time to clean all parts thoroughly to ensure creak-free shredding.
- ✗ Apply Ti. Prep or Anti-Seize to threads of forward and rear shock mounting hardware (parts M and S in exploded view).
- ✗ Apply grease to all axle shafts and bearing seal faces. Do not apply grease to the threads of the axles and bolts.
- ✗ Apply blue Loctite 242 (or similar) to threads on the bolts before threading them into the pivot axles.
- ✗ We recommend only changing bearings that show signs of wear.
- ✗ To make assembly easier, loosely assemble the complete linkage before tightening any of the pivot locations.

Pivot Number	Diagram	Parts List
#1	<p>Lower Link</p> <p>Front Triangle</p> <p>Drive Side</p>	<p>1x (A) 310-FRA18-0116 Pivot #1 Axle</p> <p>2x (F) 310-FRA18-0115 Pivot #1/#4 Spacer</p> <p>1x (C) 310-FRA18-0114 Pivot #1 Inner Spacer</p> <p>4x (N) ----- 6801V Bearing</p> <p>1x (K) 310-FRA18-0117 Pivot #1/#2/#4 Bolt</p> <p>Torque to 10 Nm</p>
#2	<p>Upper Link</p> <p>Front Triangle</p> <p>Drive Side</p>	<p>1x (B) 310-FRA18-0120 Pivot #2 Axle</p> <p>2x (G) 310-FRA18-0119 Pivot #2 Spacer</p> <p>1x (P) 310-FRA18-0118 Pivot #2 Inner Spacer</p> <p>4x (N) ----- 6801V Bearing</p> <p>1x (K) 310-FRA18-0117 Pivot #1/#2/#4 Bolt</p> <p>Torque to 10 Nm</p>

Pivot Assembly Overview

Pivot Number	Diagram	Parts List
#3	<p>Rear Triangle</p> <p>Front Triangle</p> <p>Upper Link</p> <p>Drive Side</p>	<p>2x (C) 310-FRA18-0122 Pivot #3 Axle</p> <p>2x (H) 310-FRA18-0121 Pivot #3 Spacer</p> <p>4x (N) ----- 6801V Bearing</p> <p>2x (L) 310-FRA18-0127 Pivot #3/#5 Bolt</p> <p style="text-align: right;">Torque to 10 Nm</p>
#4	<p>Lower Link</p> <p>Rear Triangle</p> <p>Drive Side</p>	<p>1x (D) 310-FRA18-2124 Pivot #4 Axle</p> <p>2x (I) 310-FRA18-2123 Pivot #4 Spacer</p> <p>4x (N) ----- 6801V Bearing</p> <p>1x (K) 310-FRA18-0117 Pivot #1/#2/#4 Bolt</p> <p style="text-align: right;">Torque to 10 Nm</p>
#5	<p>Shock Yoke</p> <p>Rear Triangle</p> <p>Drive Side</p>	<p>2x (E) 310-FRA18-0126 Pivot #5 Axle</p> <p>2x (J) 310-FRA18-0125 Pivot #5 Spacer</p> <p>2x (N) ----- 6801V Bearing</p> <p>2x (L) 310-FRA18-0127 Pivot #3/#5 Bolt</p> <p style="text-align: right;">Torque to 10 Nm</p>